



MODELS BE36 & BG36 Electric/Gas Conveyor Oven



OPTIONS AND ACCESSORIES (AT ADDITIONAL CHARGE)

- Cord set, locking plug and receptacle (domestic gas ovens only)
- High speed conveyor (1-10 minutes)
- Solid front
- Twin belt with individually adjustable speed settings
- One year additional extended warranty*



Project _____

Item No. _____

Quantity _____

Blodgett conveyor oven with 20" (508mm) wide conveyor assembly and 36" (915mm) baking zone length. Single, double or triple stack models.

All data is shown per oven section, unless otherwise indicated.

EXTERIOR CONSTRUCTION

- Stainless steel front, top, bottom and sides
- Aluminized steel back
- Full drop down front window

INTERIOR CONSTRUCTION

- Stainless steel outer plates
- Stainless steel wire mesh conveyor belt assembly
- Two blower inlets in the plenum for air circulation
- Upper and lower air fingers

OPERATION

- Heat transferred through forced convection (impingement)
- Open vented baking compartment
- Solid state digital controls to display set point and actual temperature as well as belt speed
- Electronic spark ignition control system (gas model)
- Atmospheric type burner (gas model)
- Internal gas pressure regulator (gas model)
- Tubular resistance elements (electric model)
- Solid state speed control with motor feedback
- Two circulation blower motors
- 3-30 minute bake time

STANDARD FEATURES

- Front mounted digital control
- Large front loading door with window and stainless steel handle
- Folding removable conveyor belt assembly
- Adjustable belt tensioning feature
- Field reversible belt direction
- One 8" extension tray
- Product stop
- Flexible gas hose with quick disconnect and restraining device
- Lower shelf on single and double stack ovens
- Oven start-up*
- One year parts & labor warranty*

* For all international markets, contact your local distributor.

BE36 & BG36

BLODGETT OVEN COMPANY

www.blodgett.com

1400 Toastmaster Drive, Elgin, IL USA 60120 • Phone: (847) 741-3300 • Fax: (847) 741-0015



MODEL BE36 & BG36



APPROVAL/STAMP

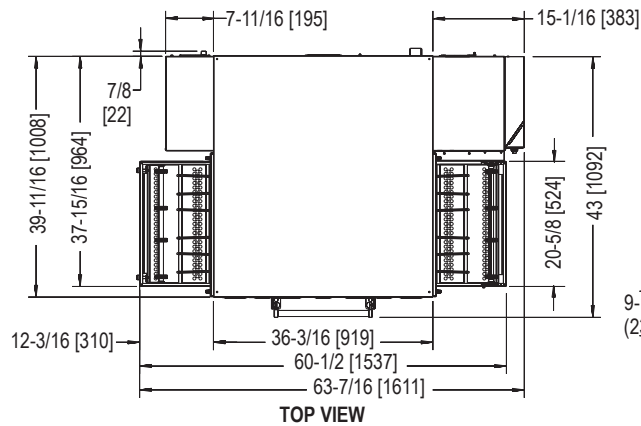

DIMENSIONS ARE IN INCHES [MM]

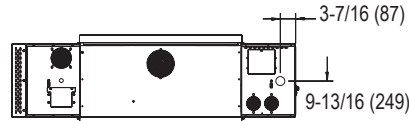

BE36 REAR VIEW

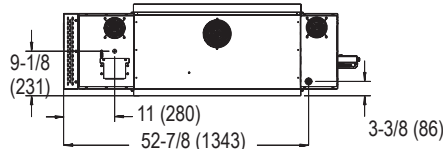

BG36 REAR VIEW

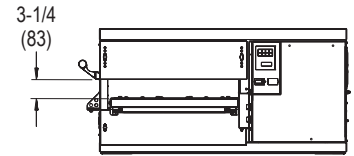

END VIEW

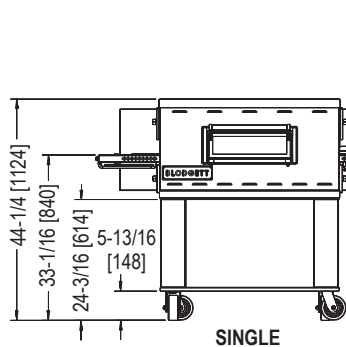

SINGLE

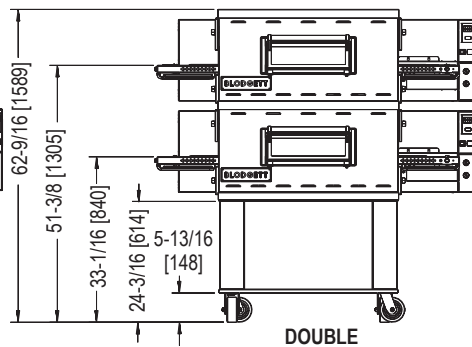

DOUBLE

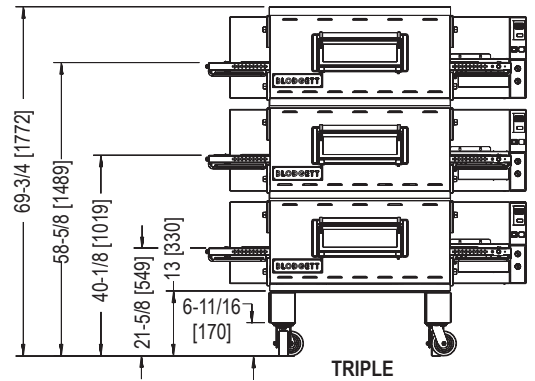

TRIPLE

SHORT FORM SPECIFICATIONS

Provide Blodgett conveyor model BE36 (electric) or BG36 (gas) conveyor oven. Unit shall cook by means of forced, heated air. Unit shall be (single/double/triple) deck. Each deck shall be fully independent, of stainless steel construction, and fully insulated on all sides. Provide with (electronic spark ignition gas fired/electrically heated) baking compartment with two blowers to evenly distribute heat across baking zone. Conveyor belts shall be single - 18" (457mm) belt constructed of stainless steel wire mesh; baking zone length shall be 36" (915mm). Unit shall be provided with drop down front window. Control panel shall be solid state with 550°F (288°C) maximum thermostat and LCD display of 3-30 minutes adjustable belt speed. Provide start-up inspection service by a factory authorized service agent. Provide options and accessories as indicated.

DIMENSIONS:

Floor space	60" (1524mm) W x 43" (1092mm) L		
Product clearance	3-1/4" (83mm)		
Combustible wall clearance	Left	Right	Rear
BE36	0" (0mm)	0" (0mm)	3" (76mm)
BG36	1" (25mm)	1" (25mm)	3" (76mm)
Baking zone			
Width	20" (508mm)		
Length	36" (914mm)		

MAXIMUM INPUT: (per section)

BE36	17 kW
BG36	76,000 BTU/hr (22 KW) (80 MJ/hr)

GAS SUPPLY: (specify)

	Natural	Propane
Oven per cavity	1/2" NPT	1/2" NPT
Main gas supply	2" line	1-1/2" line
Minimum Gas Pressure:	6" W.C.	11.0" W.C.
Maximum Gas Pressure:	12" W.C.	14" W.C.

POWER SUPPLY (must have dedicated ground)

BE36

Domestic	208 VAC, 50/60 hz, 3 ph, 47amp, 3-wire plus ground
	240 VAC, 50/60 hz, 3 ph, 41 amp, 3-wire plus ground
International	380 VAC, 50/60 hz, 3 ph, 26 amp, 3-wire plus N and ground
	480 VAC, 50/60 hz, 3 ph, 20 amp, 3-wire plus N and ground
CE	380 VAC, 50 hz, 3 ph, 26 amp, 3-wire plus N and ground

BG36

All	208-240 VAC, 50/60 Hz, 1 ph, 6 amp., 2-wire plus ground
-----	---

MINIMUM ENTRY CLEARANCE:

Uncrated	19-1/2" (495mm)
----------	-----------------

SHIPPING INFORMATION:

Approx. Weight:

Single	658 lbs. (299 kg)
Double	1255 lbs. (570 kg)
Triple	2449 lbs. (1112 kg)

NOTE: The company reserves the right to make substitutions of components without prior notice

BLODGETT OVEN COMPANY

www.blodgett.com • 1400 Toastmaster Drive, Elgin, IL USA 60120 • Phone: (847) 741-3300 • Fax: (847) 741-0015